

Description

The GC72N65 uses advanced super junction technology and design to provide excellent $R_{DS(ON)}$ and low gate charge. This device is suitable for industry AC-DC SMPS requirement of PFC, AC/DC power conversion, and other industrial power applications.

General Features

- Optimized body diode reverse recovery performance
- Low on-resistance and low conduction losses
- Small Package
- Ultra Low Gate Charge cause lower driving requirement
- 100% Avalanche Tested
- RoHS Compliant

Application

- Power Factor Correction (PFC)
- Switched Mode Power Supply (SMPS)
- Uninterruptible Power Supply (UPS)

| | | |
|----------|-----------------------------|-------|
| V_{DS} | $R_{DS(ON)}$ @ 10V (typ) | I_D |
| 650V | 35m Ω | 72 A |

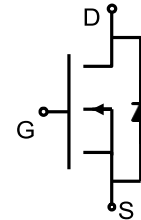

Schematic Diagram

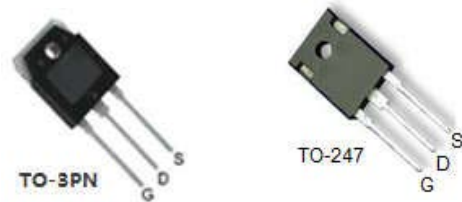

Marking and Pin Assignment

Ordering Information

| Part Number | Marking | Case | Packaging |
|-------------|---------|--------|------------|
| GC72N65P | GC72N65 | TO-3PN | 50pcs/Tube |
| GC72N65Q | GC72N65 | TO-247 | 50pcs/Tube |

Absolute Maximum Ratings ($T_C=25^\circ\text{C}$ unless otherwise noted)

| Parameter | Symbol | Value | | Unit |
|---|---------------------|------------|--------|------------------|
| | | TO-3PN | TO-247 | |
| Drain-Source Voltage | V_{DS} | 650 | | V |
| Gate-Source Voltage | V_{GS} | ± 30 | | V |
| Drain Current-Continuous ($T_C=25^\circ\text{C}$) | I_D | 72 | | A |
| Drain Current-Continuous ($T_C=100^\circ\text{C}$) | | 43.2 | | A |
| Drain Current-Pulsed (Note 1) | I_{DM} | 216 | | A |
| Single Pulse Avalanche Energy (Note 2) | E_{AS} | 2185 | | mJ |
| Repetitive Avalanche Energy (Note 1) | E_{AR} | 3.31 | | mJ |
| Avalanche Current (Note 1) | I_{AR} | 13.7 | | A |
| Maximum Power Dissipation ($T_C=25^\circ\text{C}$) | P_D | 500 | | W |
| MOSFET dv/dt ruggedness, $V_{DS} = 0 \dots 480\text{V}$ | dv/dt | 50 | | V/ns |
| Reverse diode dv/dt, $V_{DS} = 0 \dots 480\text{V}$, $I_{SD} \leq I_D$ | di _F /dt | 15 | | V/ μs |
| Operating Junction and Storage Temperature Range | T_J, T_{STG} | -55 To 150 | | $^\circ\text{C}$ |

Thermal Characteristic

| Parameter | Symbol | Value | | Unit |
|---|------------|--------|--------|---------------|
| | | TO-3PN | TO-247 | |
| Thermal Resistance,Junction-to-Case | R_{thJC} | 0.25 | | $^{\circ}C/W$ |
| Thermal Resistance,Junction-to-Ambient (Note 2) | R_{thJA} | 62 | | $^{\circ}C/W$ |

Electrical Characteristics ($T_A=25^{\circ}C$ unless otherwise noted)

| Parameter | Symbol | Condition | Min | Typ | Max | Unit |
|--|--------------|--|-----|------|-----------|------------|
| Off Characteristics | | | | | | |
| Drain-Source Breakdown Voltage | BV_{DSS} | $V_{GS}=0V, I_D=250\mu A$ | 650 | - | - | V |
| Zero Gate Voltage Drain Current ($T_J=25^{\circ}C$) | I_{DSS} | $V_{DS}=650V, V_{GS}=0V$ | - | - | 1 | μA |
| Zero Gate Voltage Drain Current ($T_J=125^{\circ}C$) | I_{DSS} | $V_{DS}=650V, V_{GS}=0V$ | - | - | 100 | μA |
| Gate-Body Leakage Current | I_{GSS} | $V_{GS}=\pm 30V, V_{DS}=0V$ | - | - | ± 100 | nA |
| On Characteristics (Note 3) | | | | | | |
| Gate Threshold Voltage | $V_{GS(th)}$ | $V_{DS}=V_{GS}, I_D=250\mu A$ | 2.5 | - | 4.5 | V |
| Drain-Source On-State Resistance | $R_{DS(ON)}$ | $V_{GS}=10V, I_D=25A$ | - | 35 | 40 | m Ω |
| Gate resistance | R_G | $f = 1.0MHz$ open drain | - | 0.3 | - | Ω |
| Dynamic Characteristics (Note4) | | | | | | |
| Input Capacitance | C_{iss} | $V_{DS}=100V, V_{GS}=0V,$ $f = 1.0MHz$ | - | 7551 | - | PF |
| Output Capacitance | C_{oss} | | - | 265 | - | PF |
| Reverse Transfer Capacitance | C_{rss} | | - | 28 | - | PF |
| Switching Characteristics (Note 4) | | | | | | |
| Turn-on Delay Time | $t_{d(on)}$ | $V_{DD}=400V, I_D=50A,$ $R_{GEN}=25\Omega$ | - | 45 | - | ns |
| Turn-on Rise Time | t_r | | - | 161 | - | ns |
| Turn-Off Delay Time | $t_{d(off)}$ | | - | 287 | - | ns |
| Turn-Off Fall Time | t_f | | - | 87 | - | ns |
| Total Gate Charge | Q_g | $V_{DD}=520V, I_D=50A,$ $V_{GS}=10V$ | - | 160 | - | nC |
| Gate-Source Charge | Q_{gs} | | - | 38 | - | nC |
| Gate-Drain Charge | Q_{gd} | | - | 60 | - | nC |
| Drain-Source Diode Characteristics | | | | | | |
| Continuous Body Diode Current | I_S | $T_C=25^{\circ}C$ | - | - | 72 | A |
| Pulsed Diode Forward Current | I_{SM} | $T_C=25^{\circ}C$ | - | - | 216 | A |
| Diode Forward Voltage | V_{SD} | $T_J=25^{\circ}C,$ $I_{SD}=72A, V_{GS}=0V$ | - | 0.9 | 1.2 | V |
| Reverse Recovery Time | t_{rr} | $V_R=400V, I_F=30A,$ $di_F/dt = 100A/\mu s$ | - | 540 | - | ns |
| Reverse Recovery Charge | Q_{rr} | | - | 13.5 | - | μC |
| Peak Reverse Recovery Current | I_{rrm} | | - | 50.4 | - | A |

Notes:

1. Repetitive Rating: Pulse width limited by maximum junction temperature.
2. $I_{AS} = 13.7A, V_{DD} = 50V, R_G = 25\Omega, \text{Starting } T_J = 25^{\circ}C$
3. Pulse Test: Pulse Width $\leq 300\mu s, \text{Duty Cycle } \leq 1\%$.
4. Guaranteed by design, not subject to production

Typical Electrical And Thermal Characteristics

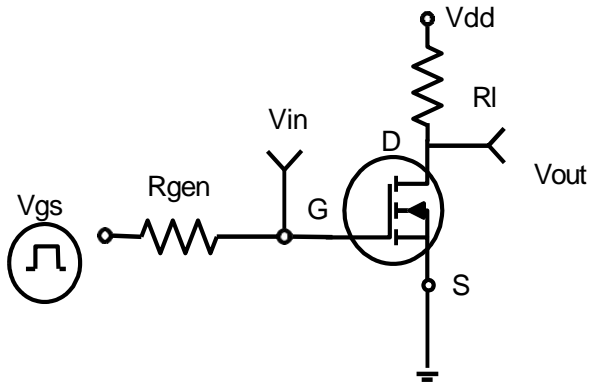

Figure 1. Switching Test Circuit

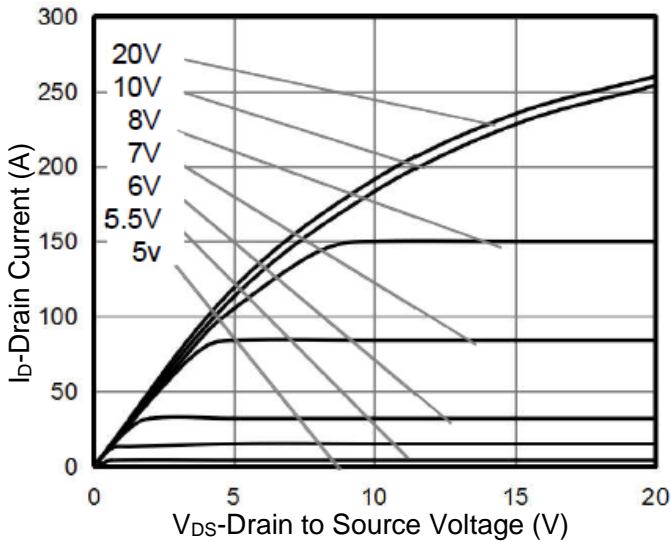

Figure 3. Output Characteristics

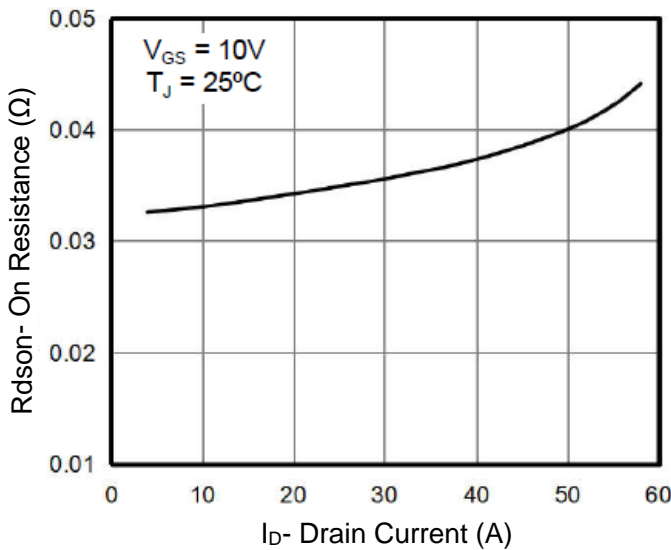

Figure 5. On Resistance vs. Drain Current

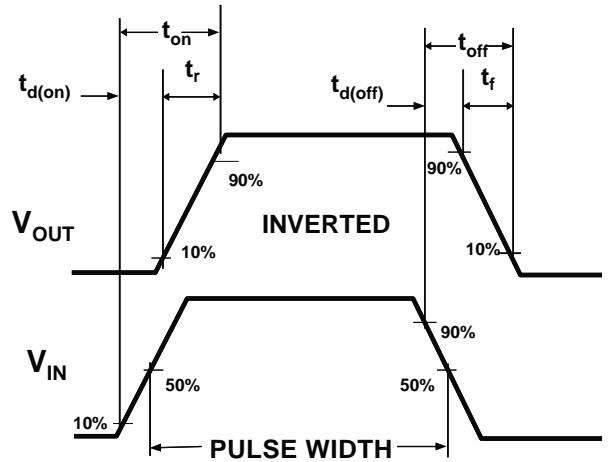

Figure 2. Switching Waveforms

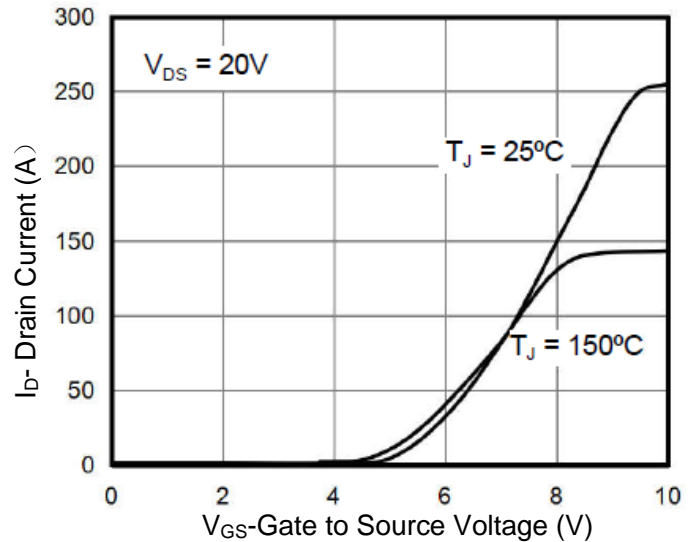

Figure 4. Transfer Characteristics

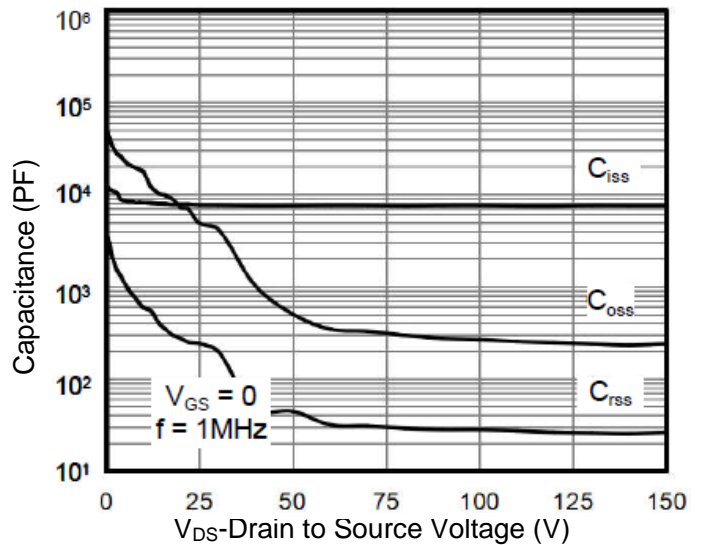

Figure 6. Capacitance

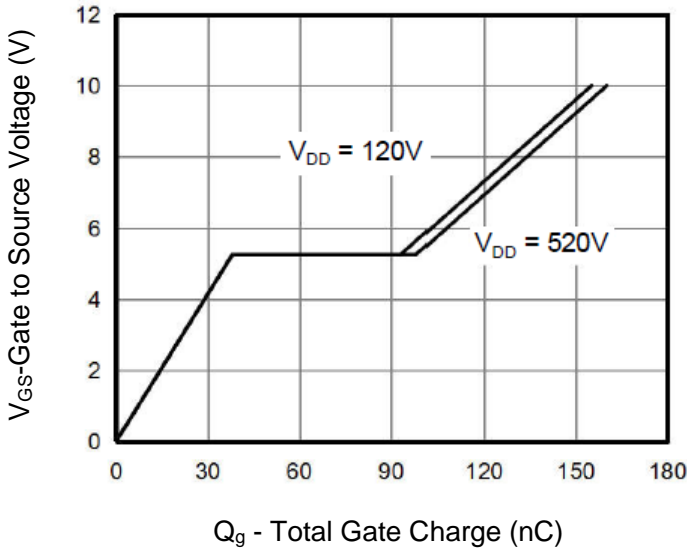

Figure 7. Gate Charge

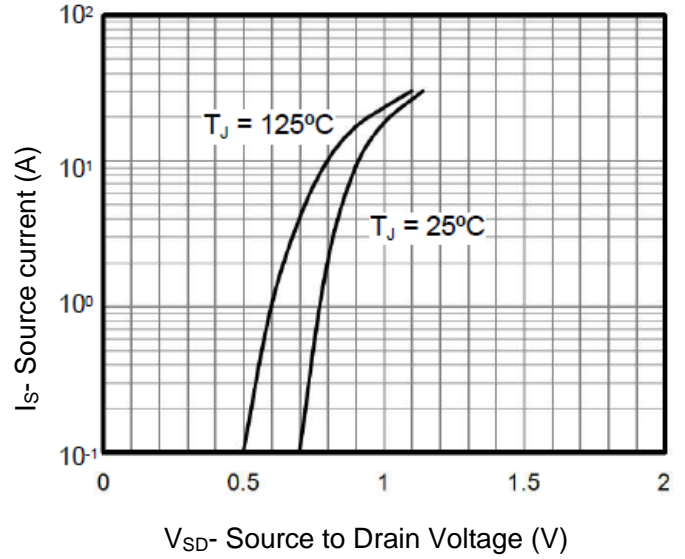

Figure 8. Body Diode Forward Voltage

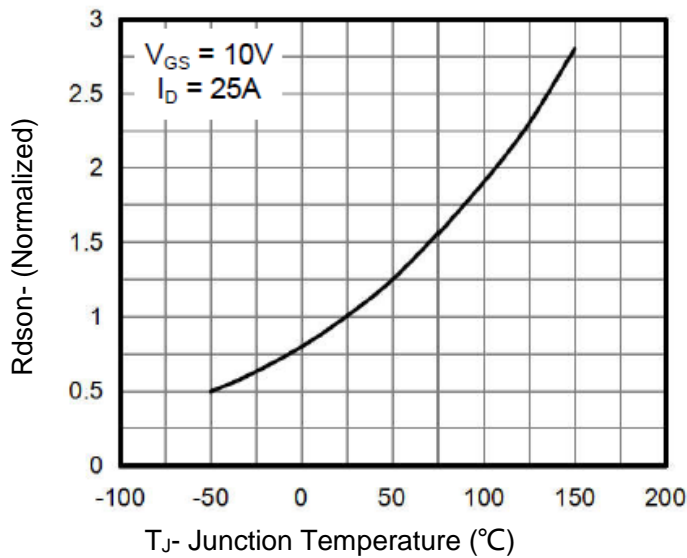

Figure 9. On- Resistance vs. Junction Temperature

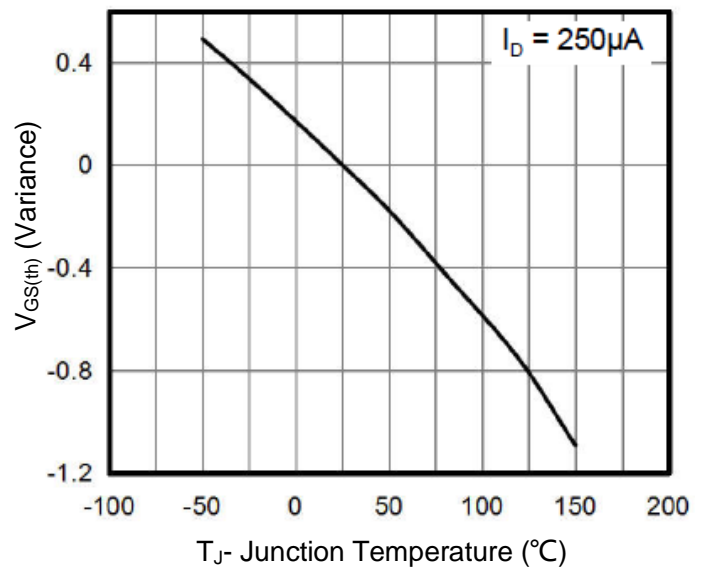

Figure 10. Threshold Voltage vs. Junction Temperature

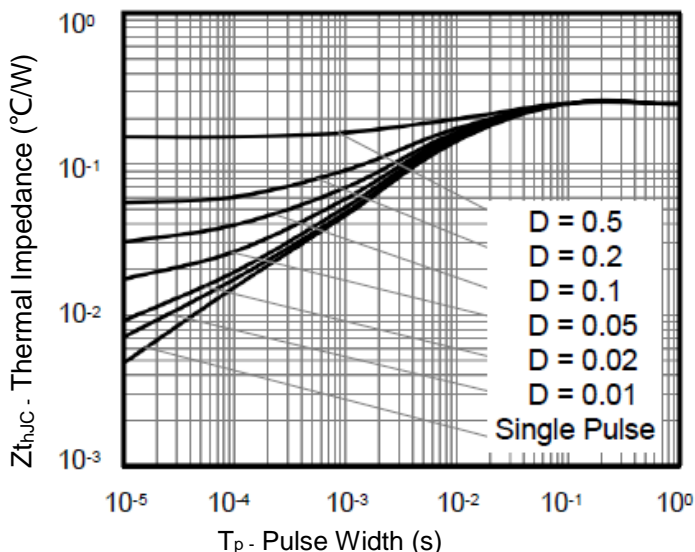

Figure 11. Transient Thermal Impedance (TO-3PN/TO-247)

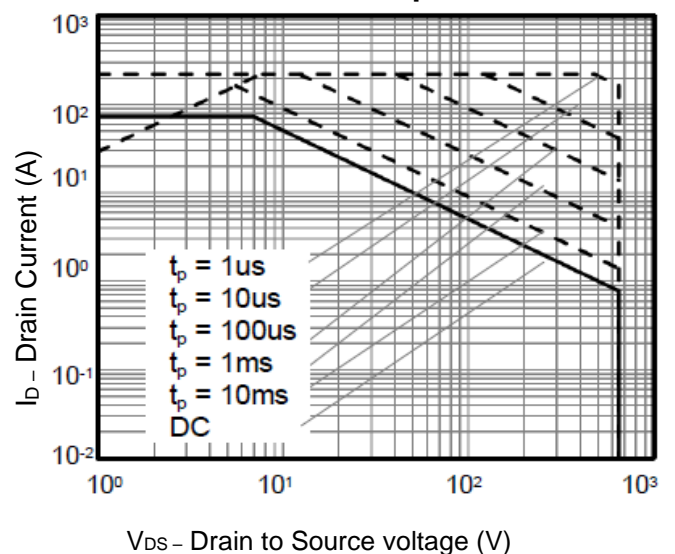
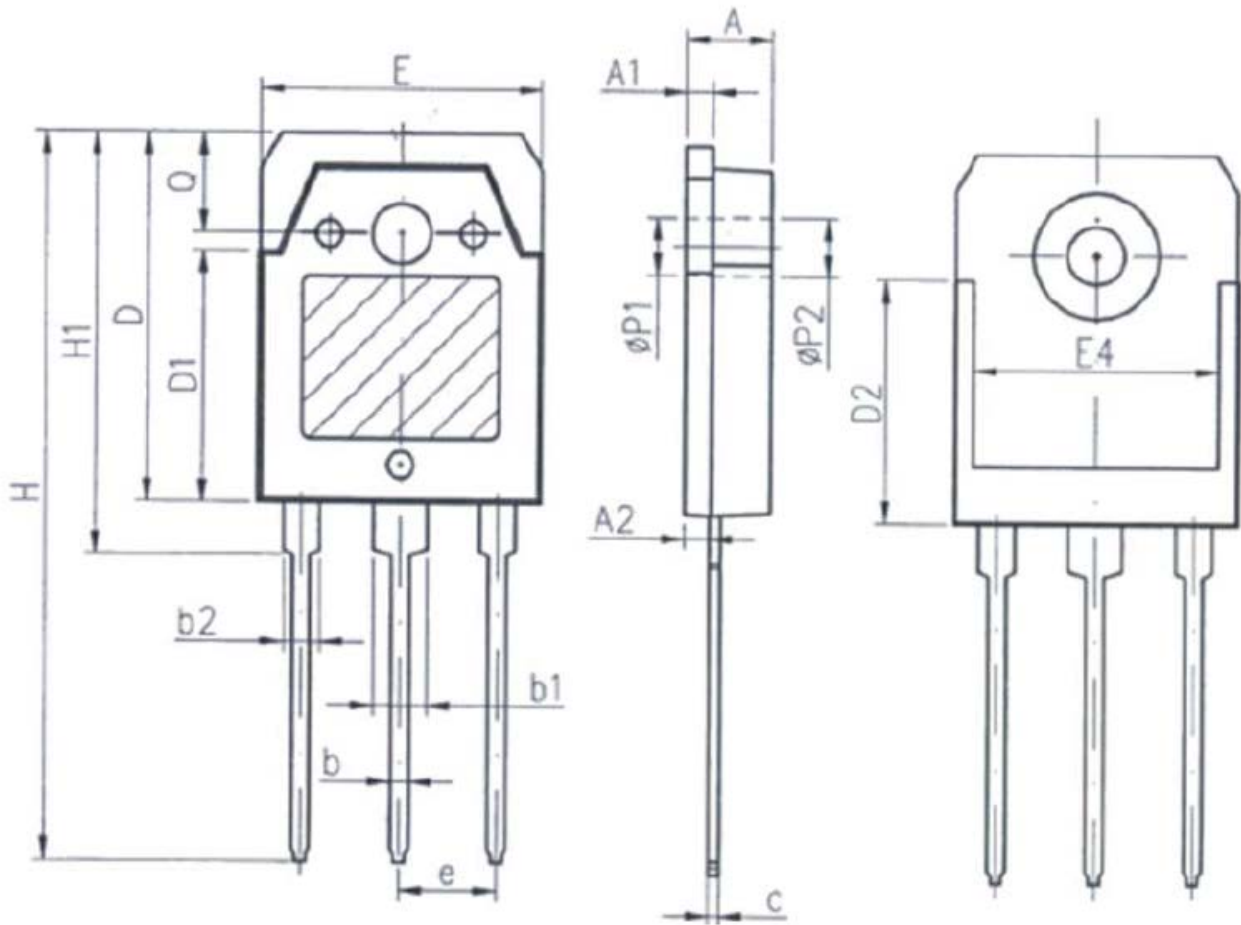

Figure 12. Safe Operation Area for TO 3PN/TO 247

TO-3PN Package Information



| Unit: mm | | |
|----------|---------|-------|
| Symbol | Min. | Max. |
| A | 4.6 | 5 |
| A1 | 1.4 | 1.65 |
| A2 | 1.18 | 1.58 |
| b | 0.8 | 1.2 |
| b1 | 2.8 | 3.2 |
| b2 | 1.8 | 2.2 |
| c | 0.5 | 0.75 |
| D | 19.6 | 20.2 |
| D1 | 13.55 | 14.25 |
| D2 | 12.9REF | |
| E | 15.35 | 15.85 |
| E4 | 12.6 | - |
| e | 5.45TYP | |
| H | 40.1 | 40.9 |
| H1 | 23.15 | 23.65 |
| P1 | 3.2REF | |
| P2 | 3.5REF | |

TO-247 Package Information

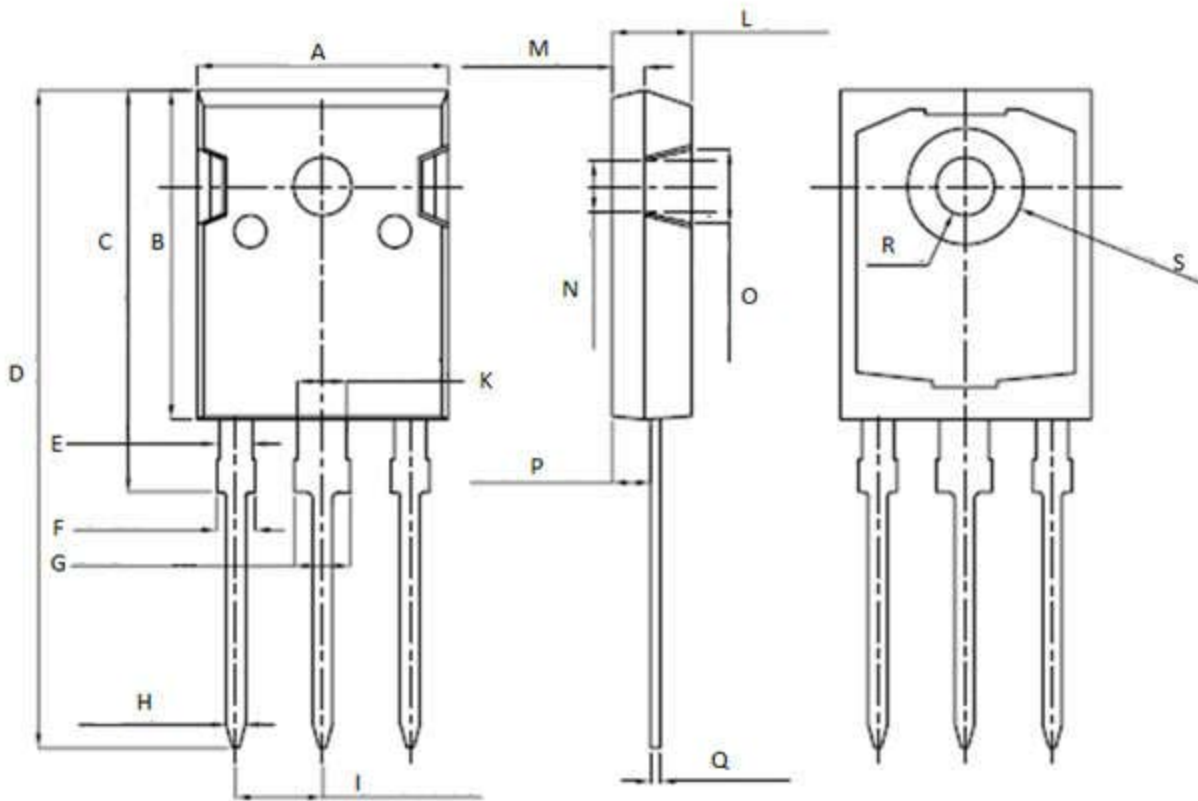

| Unit: mm | | |
|----------|-------|-------|
| Symbol | Min. | Max. |
| A | 15.95 | 16.25 |
| B | 20.85 | 21.25 |
| C | 20.95 | 21.35 |
| D | 40.5 | 40.9 |
| E | 1.9 | 2.1 |
| F | 2.1 | 2.25 |
| G | 3.1 | 3.25 |
| H | 1.1 | 1.3 |
| I | 5.40 | 5.50 |

| Unit: mm | | |
|----------|------|------|
| Symbol | Min. | Max. |
| K | 2.90 | 3.10 |
| L | 4.90 | 5.30 |
| M | 1.90 | 2.10 |
| N | 4.50 | 4.70 |
| O | 5.40 | 5.60 |
| P | 2.29 | 2.49 |
| Q | 0.51 | 0.71 |
| R | Φ3.5 | Φ3.7 |
| S | Φ7.1 | Φ7.3 |